

# Agricultural Track Service Guide

## Removal, Installation, Inspection and Alignment



**Caterpillar Challenger 35, 45, 55**  
**John Deere 8000T, 8020T Series**  
**John Deere 9000T, 9020T Series**

CPB-0316  
05/04



## Table of Contents

Introduction .....	1
Track Terminology .....	1
General Tooling Requirements .....	2
Time Estimates - Removal, Installation and Alignment .....	2
Tractor Preparation .....	2
Track Removal.....	3
Undercarriage Inspection.....	7
Installation of Replacement Track.....	9
Track Alignment.....	11
Track Alignment Check (JD 8000T and Cat 35/45/55 only) .....	11
Track Alignment Adjustment.....	11

## Introduction

This service guide is intended for use for distributors and dealers, and provides the basic information needed for track installation and service. Whenever tracks are changed, they also require alignment in order to maximize overall track life.

### Notice

When servicing track machines, follow all manufacturers recommended safety precautions.  
Failure to follow safe procedures can result in injury or death.

## Track Terminology

For reference with the rest of the following document, the terms used are referenced above. Familiarize yourself with the terms below before reading further instructions or working on any tracked machine.

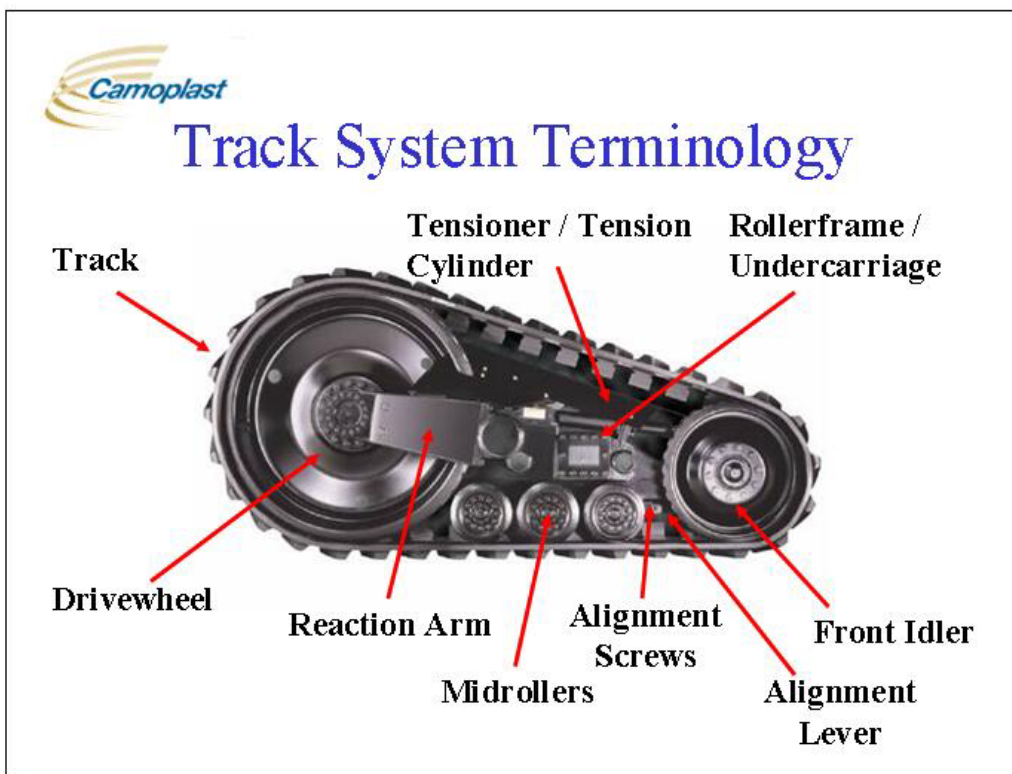

## General Tooling Requirements

Table 1 lists both the standard and specialized tools required for the removal, installation and alignment of Camoplast tracks. Refer to publication list CPB-0330 “Agricultural Track Technical Literature and Tooling List” for the list of specialized tools available from Camoplast.

<b>Safety Glasses and Steel Toed Shoes</b> <b>CST- 0300 Detensioning Kit*</b> <b>Pilot Pins (for idler / idler weight installation)</b> <b>Air Impact Socket Set (up to 1 ½”)</b> <b>Ratcheting hoist / “Come Along”</b> <b>Selection of pry bars</b> <b>Infrared Thermometer*</b> <b>Torque Wrench (600 ft-lb capacity)</b> <b>(4) [15 Ton Minimum] Support Stands</b>	<b>1” Air Impact Wrench (with 450 ft-lb capacity)</b> <b>Several large wood blocks</b> <b>(2) Lifting Eyes</b> <b>Air / Hydraulic Jack (min 15 Ton Capacity / 12” stroke)</b> <b>Soap solution (Track installation)</b> <b>15/16” or 24 mm combination wrench</b> <b>10 mm internal hex wrench (Cat adjusting screw)</b> <b>17 mm external hex (Cat later adjusting screw)</b> <b>30 mm external hex (Jam nuts)</b>
<b>Table 1. Tooling List (* denotes special track tools)</b>	

## Time Estimates - Removal, Installation and Alignment

The time required to change a track depends to a great degree on the skill of the technician and the tools available. Table 2 lists average times for removal, installation, and alignment. This estimate is based on a service technician of average skills with the basic correct tools and working on firm, level ground. Working in adverse conditions can take significantly longer, while experienced technicians will be able to work in a shorter time. 2 individuals in general can cut total man hours as compared to 1 person.

Note: If, as a result of the inspection of the machine parts need to be replaced on the undercarriage, then total time may be significantly longer than shown.

Track Removal, Inspection & Installation		Track Alignment		Total
Single Track (man hrs)	Machine (man hrs)	Single Track (man hrs)	Machine (man hrs)	Total Time (man hrs)
<b>2</b>	<b>4</b>	<b>0 - 0.5*</b>	<b>0-1*</b>	<b>4-5</b>

\* 9000T can not be aligned – no alignment time needed

**Table 2. Estimated man hours required for average track set installation and alignment**

## Tractor Preparation

1. If possible, always move the tractor to a flat, firm surface. The machine can be jacked much easier and will be more stable if the track removal and installation on a stable surface. A hard surface also makes it easier to slide the track out from under the machine, and allows use of a forklift if available.
2. Make sure that any implements are disconnected from the hitch or drawbar. Never work on a tractor with an implement attached or in the air, as this is an unstable condition.
3. Clean the tractor before working on it. Dirt and debris makes access to bolts difficult.

**Important: Record new track serial numbers in the operators guide in the tractor, on the warranty certificate, and for your records. Guide lugs or edge strips can be damaged....so make sure to record these numbers!**

## Track Removal

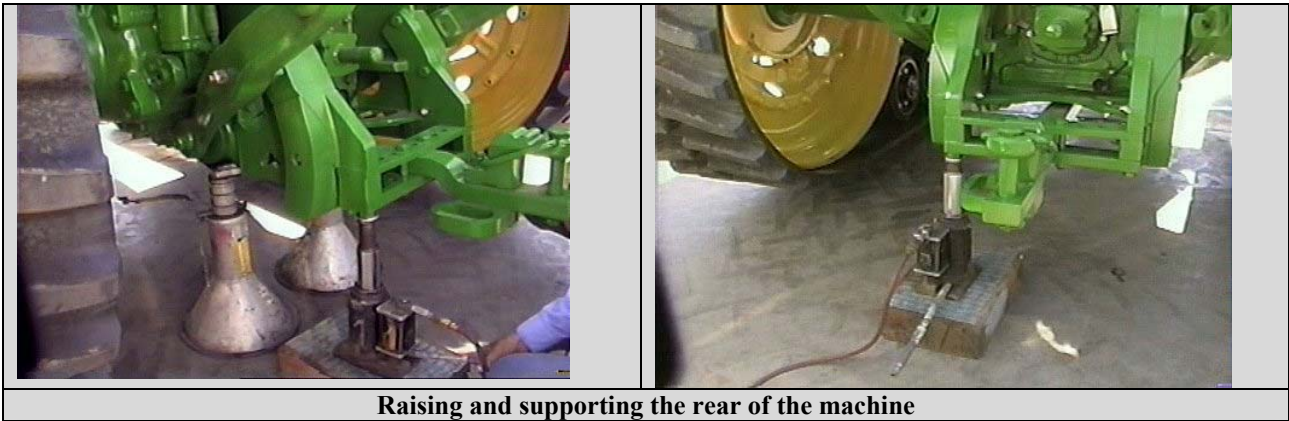

1. Raise the rear of the tractor to at least 8” above the ground. This allows enough clearance for the guide lugs to slide out from underneath the midrollers.
2. Place 2 jack stands under the drawbar support. Spread them as far apart as possible for increased stability.



3. Raise the front end of the tractor approximately 8”. Possible jacking points include the hardbar (LH Photo) or the counterweight mounting brackets (RH photo).
4. Place 2 tall jack stands to support and further stabilize the tractor.

## Detension the Track

1. Remove from the toolbox and inspect the CST-0100 Camoplast Detensioning Hose Kit. This detensioning hose kit will service the Challenger 35/45/55, as well as the JD 8000T and 9000T tractors. The gate valve (B) is used with the Caterpillar 35/45/55. The ball valve (C) is used with the JD series, and is attached to the end of the Cat hose section when working on those machines...



“L” adapter and drain hose – Used to bleed air out of the tensioning system on Caterpillar 35/45/55

Valve (C) – 8000/9000T – connects as shown (arrow)

Gate Valve (B) – Cat 35/45/55.  
Gage is installed in tee shown (arrow)

Optional OEM Manuals (in CPB-0300 Literature Kit)

2. Locate the charging port on the undercarriage. Remove the dust cap. Make sure the valves are CLOSED. Then attach the hose to the coupling.



**Charging Port Location 8000T/9000T**



**Charging Port Location Caterpillar 35/45/55**

3. Connect the opposite end of the detensioning hose to the #1 hydraulic valve at the rear of the machine.



**#1 Implement Valve - JD**

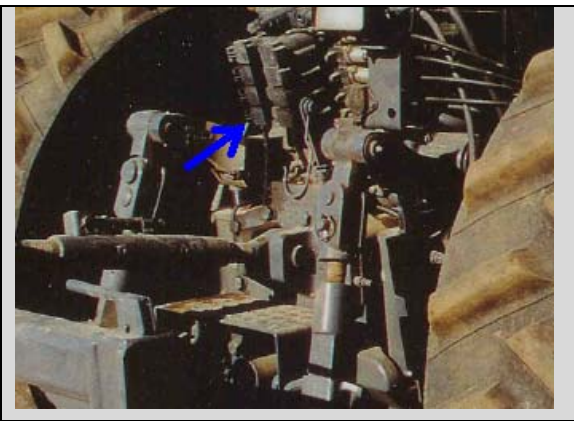

**#1 Implement Valve - Caterpillar**

4. Locate the #1 hydraulic valve control lever in the operators compartment.



**John Deere #1 Hydraulic Valve control**



**Caterpillar #1 Hydraulic Valve control**

5. At this point, the detensioning procedure differs between the JD machines and the Cat machines. Follow the correct column for the machine being worked on in order to complete this step.

**JD 8000T/9000T**

1. Open all hose hand valves.
2. Start the tractor, and move the #1 hydraulic control lever all the way forward to the "float" position.
3. Track pressure should relieve and track should slacken.

**Caterpillar 35/45/55**

1. Start the tractor, and move the #1 hydraulic lever to float and lock it in place.
2. Make sure all detensioning hose hand valves are OPEN
3. Slowly open FILLER valve (1) a maximum of 1 turn to relieve the system pressure.

6. Stop the engine. Leave the Detensioning hose connected until after Step 8.
7. (IF APPLICABLE) Using an impact wrench, remove all of the outside front idler counterweights. The counterweights weigh approximately 100 lbs each, so use a lifting eye and lifting device during removal.



**Removing front Counterweights**

8. Remove the remainder of the front idler bolts, and then remove the front idler.



**Front Idler Removal (John Deere)**



**Front Idler Removal (Caterpillar 35/45/55)**

9. If the tension cylinder is still partially extended. It will greatly help in track installation later if you use a come-along (LH photo) to pull the swing link back to within 1.5” of exposed chrome (RH photo). This can be accomplished by using the following steps:

- a) Restart the tractor.
- b) Move the #1 hydraulic valve to the FLOAT position
- c) Install and ratchet come-along to pull back the swing link and compress tension cylinder to 1.5” of exposed chrome minimum. Stop at this point. Any further movement can damage the grease zerk at the base of the swing link on the 8000T.
- d) JD 8000T/9000T – Close detensioning hose valve (C).  
Caterpillar 35/45/55 – Use a wrench to close filler valve (1).
- e) Turn off the tractor, and move the #1 lever to the HOLD position.
- f) Disconnect detensioning hose



**Use “come along” to retract tensioner**

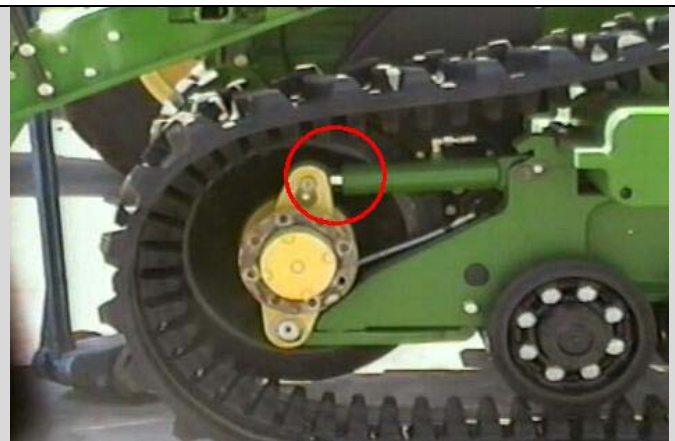

**Swing link retracted to 1.5” of visible chrome**

Please note: removal of the track will require the use of either a forklift or a boom truck, as the tracks weigh between 800 and 1500 lbs a piece. Use care when removing tracks, or injury could result.

1. Use a pry bar to work the track off the inside front idler. As an alternative, you can install a nylon strap around the track and hook it to the forklift or boom truck. Gently pull the track off the front idler.

2. With the track supported in the air, slide the rear of the track back to disengage it from the rear drivewheel.
3. Slowly slide the track out from under the midrollers, and move to a suitable location.

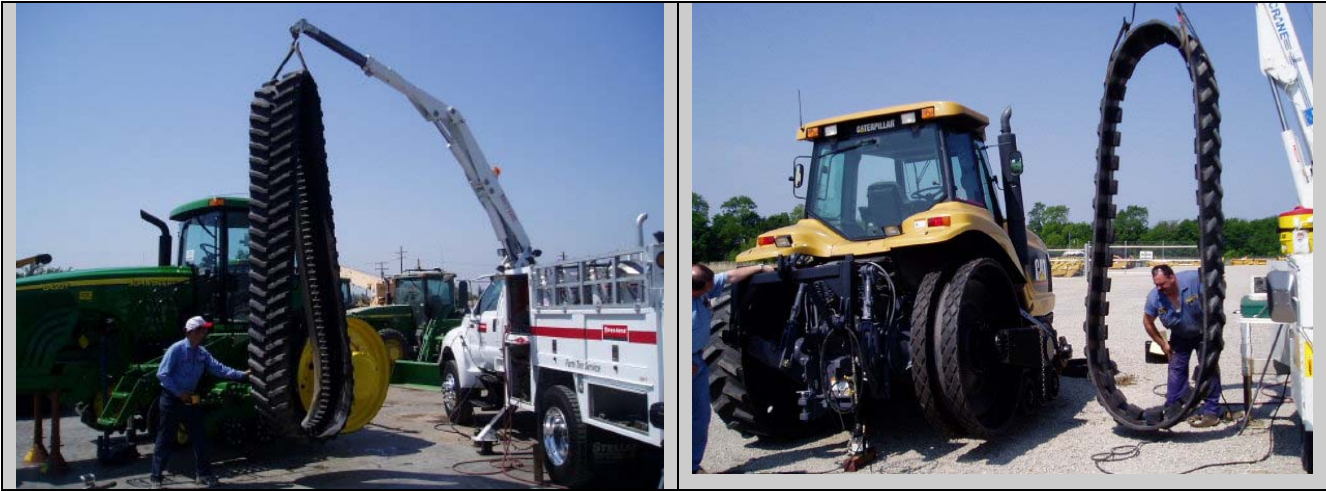

Using a boom truck to remove track (JD and Cat)

## Undercarriage Inspection

### 1. Swing Link Bushings / Adjustment Arm Bushings

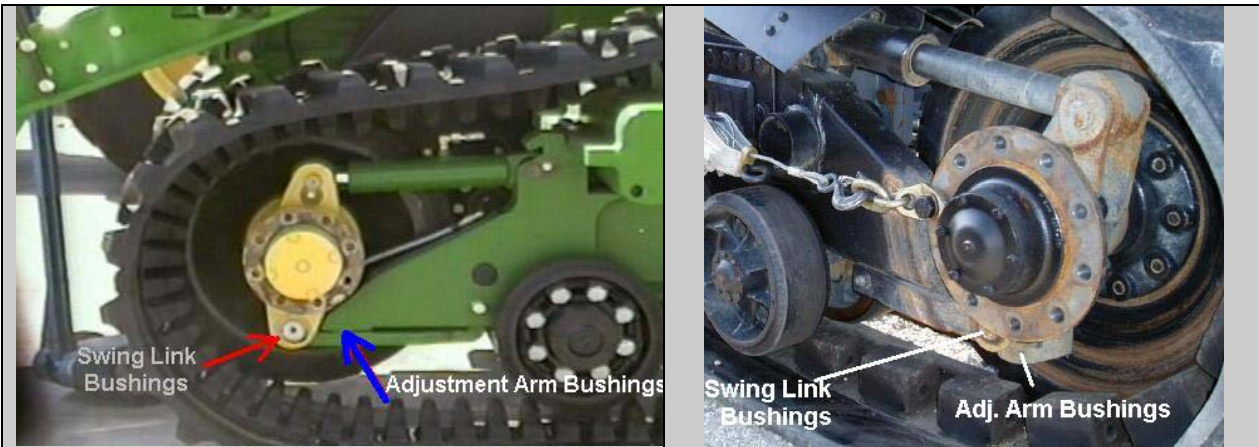

Inspection of swing link and adjustment arm bushings

**Check the wear or play in the front idler swing link bushings** - Any side to side movement of this joint indicates wear and bushings should be replaced at this time. Loose bushings will not allow the track to be properly, which can lead to rapid guide lug wear. Tractors most susceptible to bushing wear are the early Challenger 35/45/55 and the JD 8000T. Caterpillar 35/45/55 series made after 1999 (or if updated) will have sealed joints in this area and should not need service.

**Check the adjustment arm bushing for freedom of movement** – Make sure to clean all debris out of this area first. Then back out the adjustment screws on both sides of the adjustment arm, and verify that the arm will move side to side freely. If the arm will not move freely, use a lubricant and use additional force to free it up. If this arm will not move side to side, proper track alignment will not be possible.

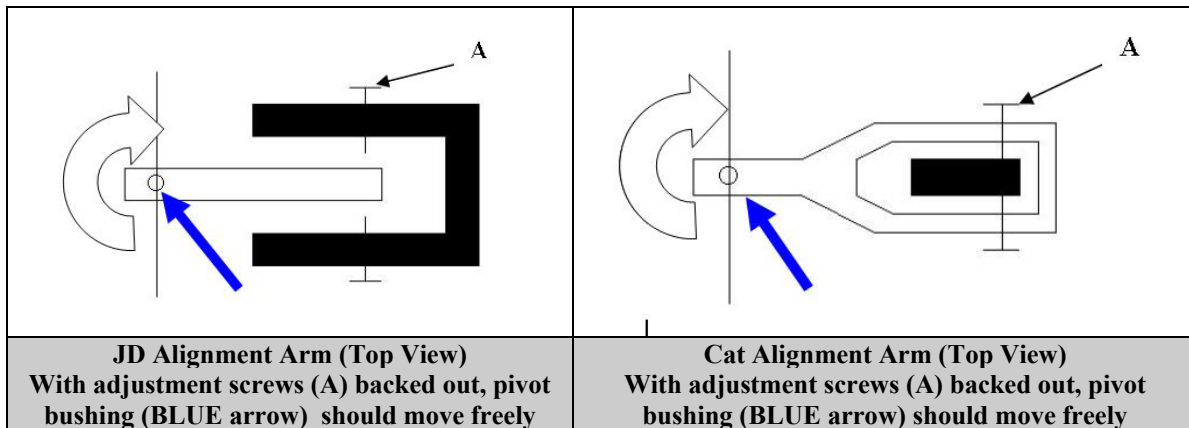

## 2. Midroller Condition

The condition of the midrollers will affect the track life. Worn or damaged midrollers can damage the track if not replaced in a timely fashion.

The general guideline for replacement of a midroller is as follows:

- More than 1/3 of the total rubber is missing around the entire midroller
- All the rubber is missing at any point all the way across the midroller
- Any flat spots are seen which may indicate midroller stopped turning



### 3. Drivewheel Condition

The drivewheel should be inspected for damaged rubber and for any cracks. If excessive rubber wear has occurred, the swing link may be extended too far forward and cause rougher ride. Check the grooves for sharpness and for depth of more than 1/8". If wear is excessive, track may not be able to tension properly and if grooves are rounded or shallow, track slippage could result.

**The drivewheel should be replaced in the following circumstances:**

- If the tread pattern depth is less than 3/16"
- If any large sections of rubber are missing
- Cracks are found in the steel
- Rubber grooves are worn down to a rounded edge

## Installation of Replacement Track

Installation of track is basically the reverse order of the removal.

1. Attach strap or chain to the new rubber track and carefully maneuver it over the rear drive wheel. You may have to use a pry bar to adjust the tracks so that the track drive lugs fall into the drive wheel slot.
2. With extreme caution, use the forklift, boom truck or pry bar to gently push the tracks under the track undercarriage.
3. Next, re-attach the strap to the front of the track and raise the track. Slip the track over the front inside idler wheel using a hoist or a forklift. Application of a soap solution to the front idler may make the installation easier.
4. Reinstall the front outside idler wheel. If counterweights were installed, also install the first (base) counterweight. Torque wheel bolts to the values listed in the table below. Make sure to follow a criss-cross sequence during tightening and retorque after tightening.

<b>Torques</b>	<b>JD 8000T/9000T</b>	<b>Caterpillar 35/45/55</b>
<b>Front Idler Bolts</b>	<b>450 ft-lbs</b>	<b>600 ft-lbs</b>
<b>Counterweight(Base)</b>	<b>450 ft-lbs</b>	<b>670 ft-lbs</b>

5. Reinstall and torque remaining counterweights (if removed earlier).
6. Tension the track.

**Note: The JD and Cat product differs again here, so follow the procedures in the following corresponding table column below to correctly tension the track.**

### 8000T/9000T



1. Open the detensioning hose valve.
2. Start the tractor, and move the #1 hydraulic control lever all the way forward to the "extend" position. The track pressure will increase and you will see the track tighten. Continue to pressurize the track until the pressure gage reads 2850 psi or higher.
3. Close the detensioning hose valve.
4. Move the hydraulic #1 lever to FLOAT (full forward) to relieve any pressure in the detensioning hose. Check that gage now reads zero.
5. Shut down the tractor.
6. Remove the detensioning hose from the tractor and replace the dust caps.

### Caterpillar Challenger 35/45/55

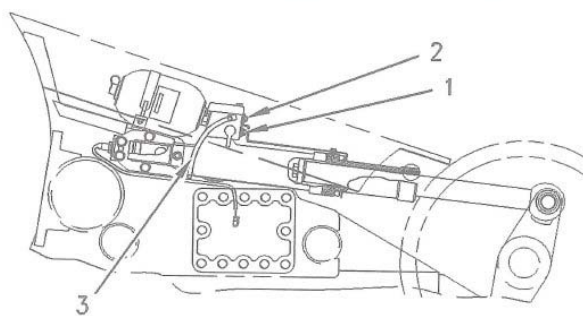

1. Make sure all hand valves are OPEN on the detensioning hose.
2. Slowly open BLEEDER valve (2)  $\frac{1}{4}$  to  $\frac{1}{2}$  a turn.
3. Direct the oil drain hose (3) into a suitable container.
4. Start the tractor, and move the #1 hydraulic lever to "extend" position (pull back) and lock it in place.
5. Now, slowly open the FILLER valve (1)  $\frac{1}{2}$  to 1/ turn.
6. Oil should start to drain into the container. Watch hose and when no large air bubbles remain, close BLEEDER valve (2).
7. Continue to charge the system, watching the pressure gage, until a pressure of 2700 psi or higher is achieved.
8. Close FILLER valve (1).
9. Move the tractor hydraulic control valve to FLOAT (full forward), to allow pressure to relieve in the detensioning hose. Check that gage now reads zero
10. Shut down tractor.
11. Remove detensioning hose from the tractor and replace the dust caps.

7. Once the track is tensioned, the opposite side track can be detensioned and the track removal procedure continued. If track installation is completed, however, then go to step 8.
8. Raise the front end and remove the front jack stands. Then lower the front end.
9. Raise the back end of the machine and remove the jack stands. Then lower the back end of the machine.

Track installation is completed. All that is left is to check and adjust alignment.

# Track Alignment

On tractors with alignment adjustment, it is very important to check the alignment after a track is installed. Tracks must always be aligned in order to maximize track and wheel life and reduce overall rolling resistance.

**Note: Failure to align the track may result in damage and or failure of the track in a short amount of time. Damage due to poor alignment is not warrantable.**

### Note

**The JD 9000T has no track alignment. Track should be centered as installed. If major misalignment is noted, contact the JD dealer to find the cause of the problem.**

## Track Alignment Check (JD 8000T and Cat 35/45/55)

1. Drive the machine forward at not faster than 5 MPH, on a flat surface, and with no steering input, for a distance of at least 200 feet.
2. Coast to a stop without steering or braking.
3. Observe the gap between the guide lugs and the rolling stock (midrollers, idlers, drivewheels) (see below). A track in alignment should have guide lugs running down the center. If guide lugs are running to one side and contacting the rolling stock, then an alignment adjustment is needed.

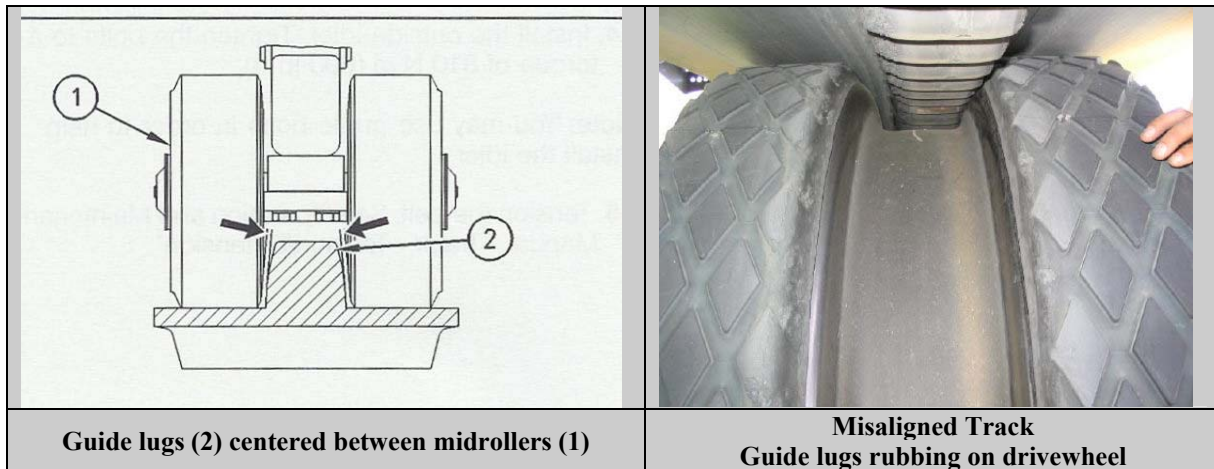

## Track Alignment Adjustment

### John Deere 8000T Series

The alignment adjustment is done by moving an alignment arm which is on the front idler. The alignment arm can be moved by use of adjustment bolts which are locked in place using locknuts.

**Note: This movement of adjustment bolts on the Caterpillar 35/45/55 is the opposite of that on the 8000T. Make sure you adjust in the correct direction.**

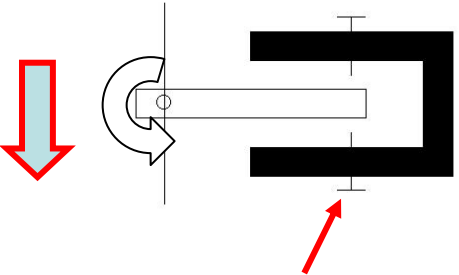
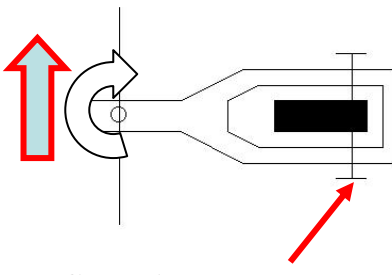
 <p><b>Clockwise Turn = Track moves LEFT</b></p>	 <p><b>Clockwise Turn = Track moves RIGHT</b></p>
<b>John Deere 8000T</b>	<b>Caterpillar 35/45/55</b>

The procedure for track alignment between the JD 8000T and Caterpillar 35/45/55 is slightly different. See the table below for the correct procedure, depending on the machine being aligned.

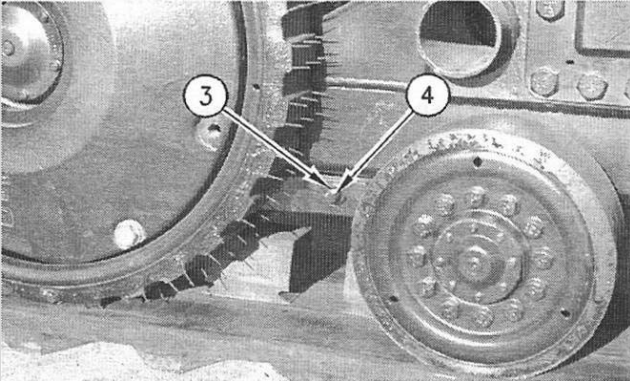
<b>John Deere 8000T Series</b>	<b>Caterpillar 35/45/55 Series</b>
 <p><b>Adjustment screw and locknut</b></p> <ol style="list-style-type: none"> <li>1. Loosen the inside and outside adjusting screw locknuts.</li> <li>2. Loosen the adjusting screw up to ½ turn on the side the guide lugs are closest. Do not adjust more than ½ turn at a time as a large amount of change can occur in alignment even with ½ turn.</li> <li>3. Tighten the opposite side bolt and torque to 41 ft-lbs.</li> <li>4. Tighten both locknuts to 120 ft-lbs.</li> <li>5. Recheck the alignment.</li> <li>6. Repeat steps 1-5 as necessary to get correct alignment.</li> </ol>	 <p><b>Adjustment screw (4) and locknut (3)</b></p> <ol style="list-style-type: none"> <li>1. Loosen the inside and outside adjusting screw locknuts</li> <li>2. Loosen the adjusting bolt up to ½ turn on the side that the guides were <u>not touching/farthest away</u>. Do not adjust more than ½ turn at a time as a large amount of change can occur in alignment even with ½ turn.</li> <li>3. Tighten the adjusting bolt on the opposite side to 41 ft-lbs.</li> <li>4. Retighten the locknuts to 120 ft-lbs.</li> <li>5. Recheck the alignment.</li> <li>6. Repeat steps 1-5 as necessary to get correct alignment.</li> </ol>

## Final Alignment Check – Temperature Differential Method

Once the alignment of the guide lugs appears centered, a final active alignment check should be done.

1. Drive the tractor in a straight line at moderate speed without steering input approximately 400 m (1300 ft ) or approximately ¼ mile.
2. Check the temperatures of the inner and outer face of the guide lug by carefully feeling the faces or using a heat gun. Note if there is any noticeable temperature difference.
3. If slight adjustment is needed, loosen the adjusting screw on the appropriate side by no more than 1/4 turn.
4. Tighten and torque the screw on the opposite side the same amount.
5. Retighten the locknuts on both sides.
6. Redo step 1 and adjust if needed until temperatures of the guide lug faces are similar on both sides.

## Warranty Information

After alignment and installation is completed, make sure to give customer the following documents:

- Warranty certificate
- Track Operational Guidelines brochure
- Warranty registration card

Take a few minutes to review the information in the brochure, and to discuss the warranty period. Also make sure to record track serial numbers on the warranty certificate for future reference.

### Summary

Installation and adjustment of tracks is straightforward and not complicated once you know the proper procedures. As you gain experience, you will find more efficient ways to accomplish the work in a shorter period of time.

For additional information on the maintenance of the undercarriage, and on the extended procedures for servicing and rebuilding these areas, refer to the proper OEM service or owners manual (available from the local OEM dealer or from Camoplast)

Title	OEM Part Number
<i>JD 8000T Operators Manual</i>	<i>OMAR178071</i>
<i>Cat 35/45/55 Operator's Manual</i>	<i>SEBU7204</i>
<i>Cat 65/75/85/95 D &amp; A Manual</i>	<i>SENR1789</i>

**Note: All OEM manuals listed above are available in a complete set by ordering the “OEM Track Installation Literature Kit“(P/N CPB-0300) from Camoplast.**

Email any suggestions for improvements, clarifications, or errors, to [Dwight.Furleigh@camoplast.com](mailto:Dwight.Furleigh@camoplast.com).