

GO-TRACT™ 3000

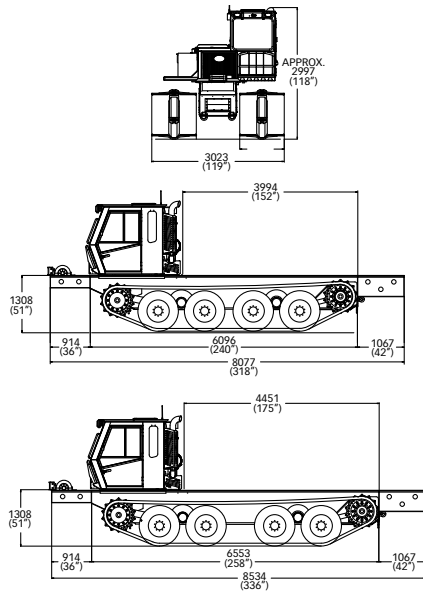

Pinotti



EPA-CERTIFIED

The EPA-certified Caterpillar engine is installed, tested and certified in conjunction with the entire vehicle. PRINOTH's commitment to exceptional quality results in this utility vehicle line-up that meets EPA Tier 3 standards.



DIMENSIONS

Overall length without extension		
STD version	6 096 mm	240 in
Stretch version	6 553 mm	258 in
Overall width		
	3 023 mm	119 in
Overall height		
	2 997 mm	118 in
Ground clearance		
	536 mm	21 in

PERFORMANCE

Curb weight (basic vehicle)		
	11 670 kg	25 728 lb
Payload		
	15 422 kg	34 000 lb
Maximum speed		
	12.9 km/h	8 mph
Fording depth		
	1 321 mm	52 in
Turning radius		
	0 m	0 in
Ground pressure (with 33 in tracks)		
Basic vehicle (STD version)	177 g/cm ² (2.52 psi)	139 g/cm ² (1.98 psi)
Basic vehicle (stretch version)	155 g/cm ² (2.21 psi)	125 g/cm ² (1.78 psi)
Loaded vehicle (STD version)	414 g/cm ² (5.89 psi)	325 g/cm ² (4.62 psi)
Loaded vehicle (stretch version)	363 g/cm ² (5.16 psi)	292 g/cm ² (4.16 psi)

Maximum gradeability

Uphill / downhill	60%	31°
Sidehill	40%	21.8°

ENGINE

Make	Caterpillar	
Model	C-7	
Type	Turbo diesel, electronic fuel system, EPA Tier III and EU Stage IIIA.	
Number of cylinders	6	
Displacement	7.24 L	442 in ³
Power @ 2 200 rpm	205 kW	275 hp
Torque @ 1 400 rpm	1 257 N·m	927 lb·ft

TRANSMISSION

	Make	Type
Pump drive	Funk	Triple pad
Hydrostatic pumps	Sauer-Danfoss	Axial, variable displacement
Hydrostatic motors	Rexroth	Axial, variable displacement
Planetaries	Bonfiglioli Trasmital	

CONTROL

Type	Microcontroller with color display
Inputs	Steering wheel, progressive front - neutral - reverse lever and speed pedal
Outputs	Independent control of each track
Other features	Anti-stall

ELECTRICAL

Voltage	12 V
Alternator	115 A
Battery capacity	2 X 950 CCA

SUSPENSION

Type	Walking beam
-------------	--------------

WHEELS

Quantity	8
Type	Solid
Dimensions	8.25 X 20

TRACKS

Type	Hardened steel with rubber belt	
Width	1 016 mm	40 in
Belt	Rubber, 6-ply	
Tensioner	Grease-filled cylinder	

CHASSIS

Type	Tub
Drain plug	Yes
Access panels	Yes

CAPACITIES

Cooling system	27 L	7 US gal
Fuel tank	350 L	92 US gal
Hydrostatic tank	63 L	16 US gal

PROVISION FOR EXTRA HYDRAULIC PUMP

Location	Top pad on triple pump drive
Flange type	SAE B - 4 in dia. pilot
Shaft type	SAE B - 13 teeth, 16/32 pitch
Direction of rotation	CCW (when looking at pump shaft)
Max rotational speed	3 390 rpm

OPTIONAL EQUIPMENT

• One-person or two-person cab	• Front and rear extensions
• Heavy duty brushguards	• Winch
• Rear pintle hook	• Blade
• External mirrors (heated available)	• High flow hydraulic capabilities for: drills, cranes, knuckle booms, man lifts, digger derricks, backhoes and many accessories
• Amber beacon light	• 7-ply belt track available
• Remote controlled directional spotlight	• 3 rd battery available
• Electronic inclinometer	
• Air conditioning	
• Arctic package	

©2009 PRINOTH Ltd. All rights reserved. ® and TM are trademarks of PRINOTH Ltd. PRINOTH Ltd. reserves the right to change or discontinue any specifications, designs, features, models or accessories shown or indicated without notice.